

HONDA

INSTALLATION INSTRUCTIONS

Accessory
WINCH MOUNT KIT
P/N 08L70-HL5-E60

Application
SXS520M2

Publication No.
MII 17623
Issue Date
December 2020

PARTS LIST

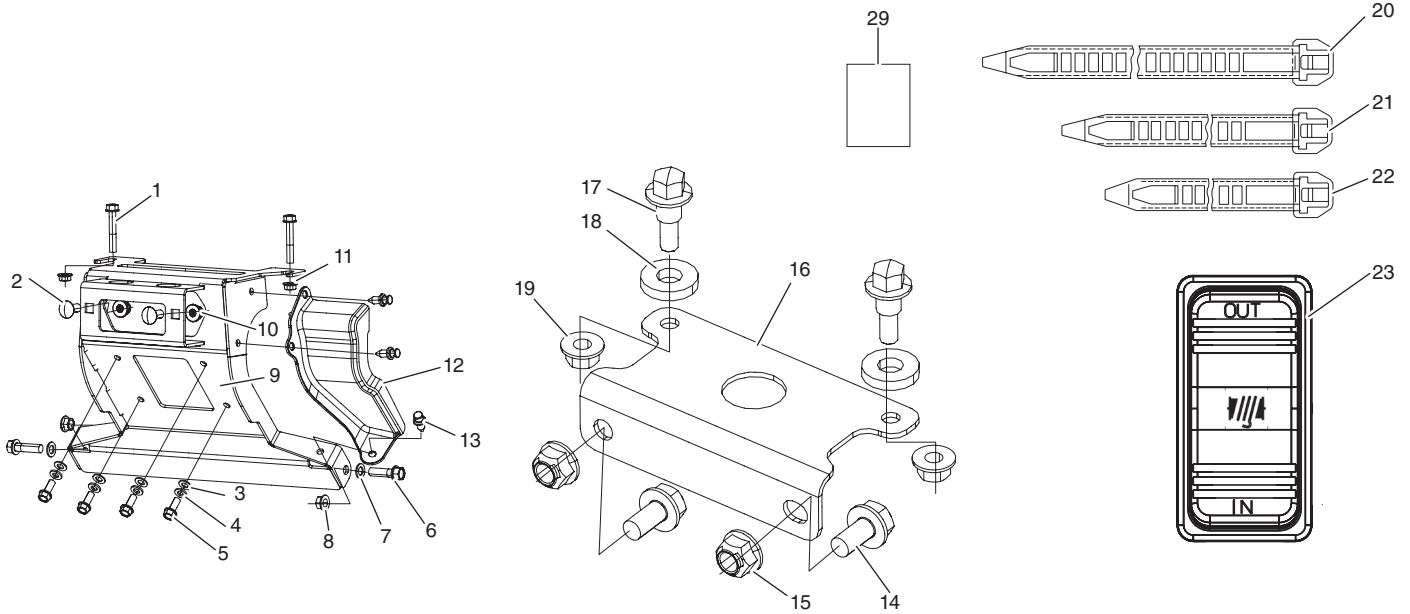

No.	Description	Qty
(1)	Flange bolt, 8 × 50 mm	2
(2)	Carriage bolt, 10 × 1.5 × 25 mm	2
(3)	Plain washer, 8 mm	4
(4)	Spring washer, 8 mm	4
(5)	Flange bolt, 8 × 25 mm	4
(6)	Flange bolt, 10 × 35 mm	2
(7)	Plain washer, 10 mm	2
(8)	Flange nut, 10 mm	2
(9)	Winch bracket	1
(10)	Lock nut, 10 × 1.5 mm	2
(11)	Flange nut, 8 mm	2
(12)	Winch Cable Cover	1
(13)	Mudguard Clip	3
(14)	Flange bolt, 6 × 12 mm	2
(15)	Lock nut, 6 mm	2
(16)	Contactor stay	1
(17)	5 mm Shoulder Bolt	2
(18)	Rubber Washer	2
(19)	5 mm Flange Nut	2
(20)	Wire tie (long)	9
(21)	Wire tie (medium)	11
(22)	Wire tie (short)	2
(23)	Winch switch	1
(24)	Winch switch sub-harness (not shown)	1

No.	Description	Qty
(25)	Winch positive cable, Yellow (not shown)	1
(26)	Winch negative cable, Blue (not shown)	1
(27)	Winch battery cable, Red (not shown)	1
(28)	Winch ground cable, Black (not shown)	1
(29)	Installation Instructions URL	1

WINCH and ACCESSORY SUB-HARNESS

Sold separately P/N 08L71-HL5-E61 & 08Z08-HL5-A00

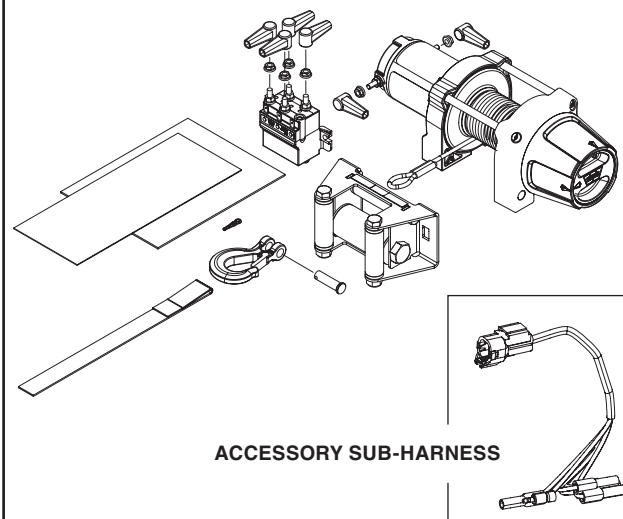

CUSTOMER INFORMATION

The information in these installation instructions is intended for use only by skilled technicians who have the proper tools, equipment, and training to correctly and safely add equipment to your SxS. These procedures should not be attempted by “Do-it-yourselfers.”

BEFORE YOU BEGIN

This kit utilizes a WARN SxS winch. Please read WARN’s Winching Technique guide provided with the winch prior to use of this product.

TOOLS AND SUPPLIES REQUIRED

Socket, (8, 10, 12, 13, 14, 15 mm)

Open end wrench (12, 13, 15 mm)

Socket extension, 6 inch

Ratchet

Torque wrench

Power drill

Drill bit (1/4 inch)

Step drill bit (with 5/8 inch capacity)

Hole saw (30 mm)

Rotary tool and carbide burr

TORQUE CHART

Tighten all screws, bolts, and nuts to their specified torque values. Refer to the Service Manual for the torque values of the removed parts.

Item	N-m	kgf-m	lbf-ft
6 mm screw	9	0.9	6.3
6 mm bolt and nut	10	1.0	7
8 mm bolt and nut	22	2.2	16
10 mm bolt and nut	34	3.5	25

USE AND CARE INFORMATION

- Check the accessory mounts frequently and retighten if necessary.
- Replace this accessory with a new one if it is damaged.
- Inspect all metal parts on the winch, winch mount and related hardware. Replace all parts that appear rusted, cracked, or deformed prior to use.
- Inspect all nuts and bolts on the winch, winch mount, and related hardware prior to each use. Tighten all nuts and bolts that are loose. Missing, stripped, fractured, or bent bolts or nuts need to be replaced immediately.
- Check all cables prior to use. Replace cables that are worn or frayed.
- Check all moving and rotating parts. Remove debris that may inhibit the free movement of any parts.

NOTICE: Failure to perform regular inspections and maintenance on the winch, winch mount, and related hardware may result in vehicle damage.

SAFETY

When installing your SxS winch system, read and follow all mounting and safety instructions. Always use caution when working with electricity and verify that there are no exposed electrical connections before energizing the winch circuit. For specifications and performance data, refer to the specification sheet supplied with the winch.

NOTE

- The 10 mm hardware included in this kit has two different thread pitches.
- Match the bolts with nuts before beginning installation to eliminate threading differently pitched hardware together. This will ensure a smooth installation.

WINCH MOTOR INSTALLATION

1. Refer to the Service Manual for the vehicle, remove front bumper.

<VIEW OF BUMPER REMOVED>

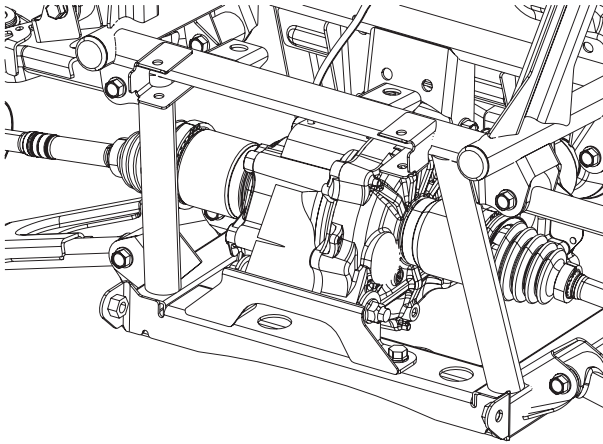

2. Install the fairlead onto the winch bracket with the 10 × 1.5 × 25 mm carriage bolts and the 10 × 1.5 mm lock nuts. Tighten the hardware to the specifications in the Torque Chart.

10 mm
CARRIAGE BOLTS

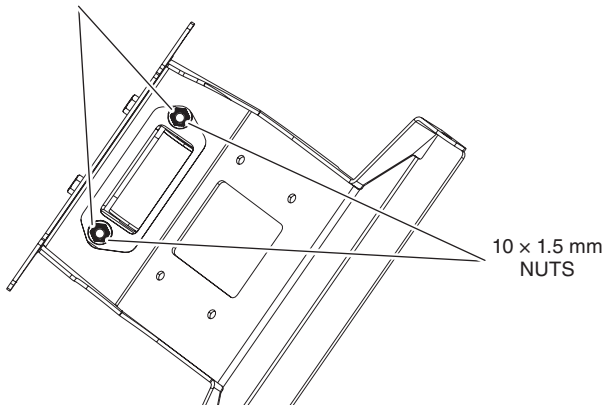

10 × 1.5 mm
NUTS

3. Connect the yellow and blue winch power cables to the winch motor with the flange nuts provided in this kit. Tighten the flange nuts securely and then pull the terminal boots over the terminals. Be sure to orient the terminals as shown.

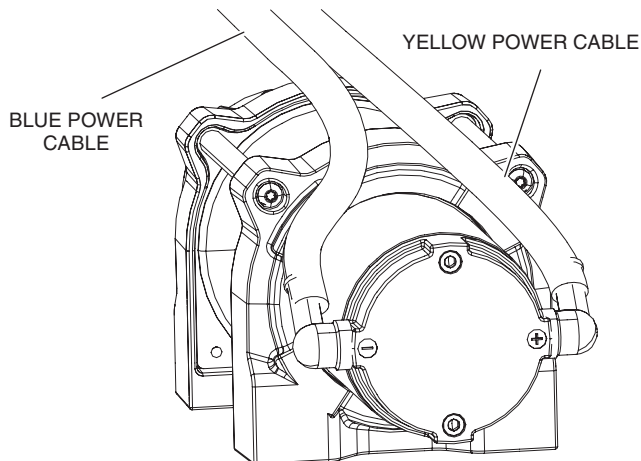

YELLOW POWER CABLE

BLUE POWER
CABLE

4. Install the winch onto the winch bracket using the 8 × 25 mm bolts, lock washers and plain washers. Be sure that the lock washer is placed between the bolt and the plain washer.

Pull the winch cable through the fairlead opening.

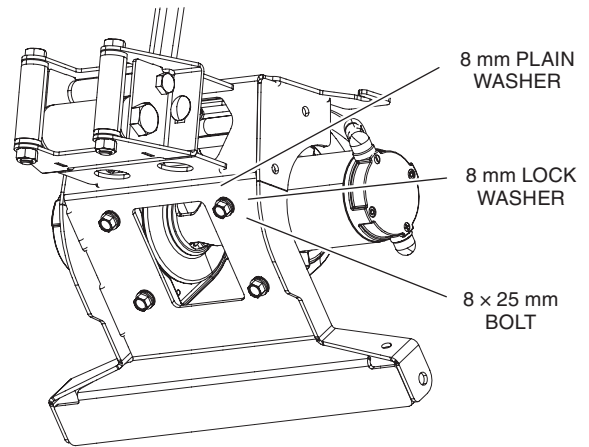

8 mm PLAIN
WASHER

8 mm LOCK
WASHER

8 × 25 mm
BOLT

Two people are required for Step 4.

5. Install the winch cable cover by inserting the three mudguard clips through the cable cover and into the winch bracket.

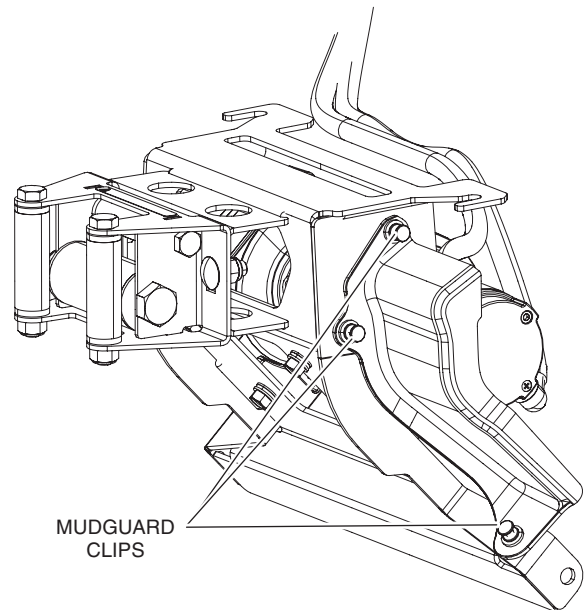

MUDGUARD
CLIPS

6. While one person supports the winch, the other person places the front bumper into its original position and inserts the 8 × 50 mm bolts through upper support brackets as shown.

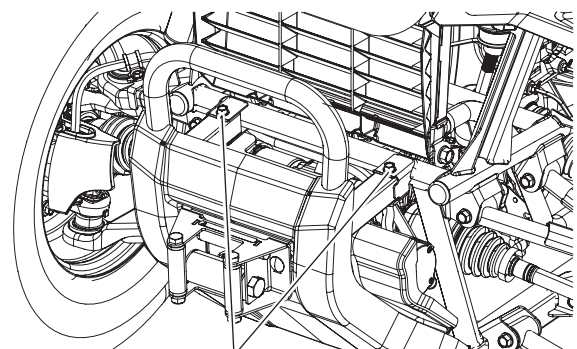

8 × 50 mm BOLTS

7. Install a 10 mm plain washer onto each 10 × 35 mm flange bolt, then pass the bolts through the lower bumper holes and tighten until the bolt emerges through the inside of the winch bracket.

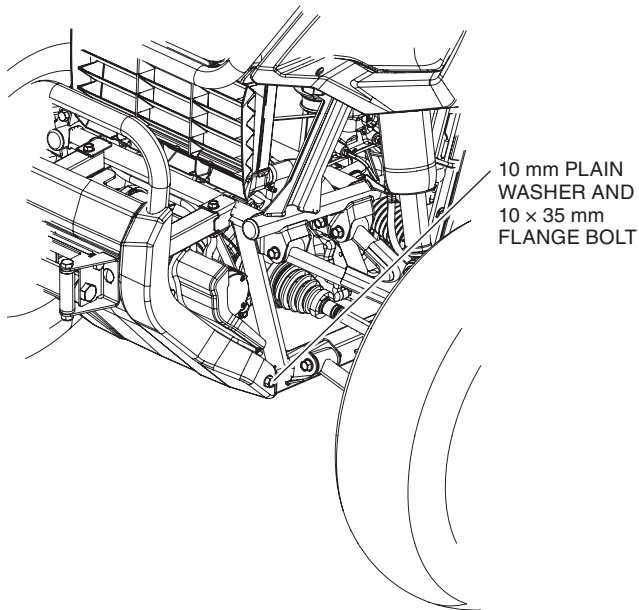

8. Install the 10 mm lock nuts on the bolts installed in Step 7. Hold the bolts and tighten the nuts to the specification in the Torque Chart.

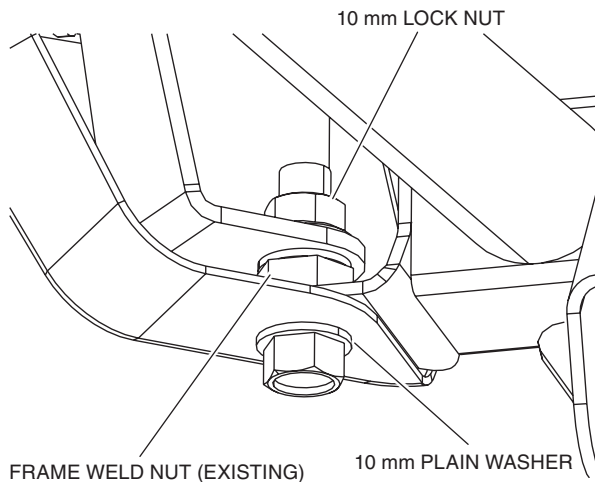

9. Install the 8 mm nuts on the two bolts installed in Step 6. Tighten them to the specification in the Torque Chart.

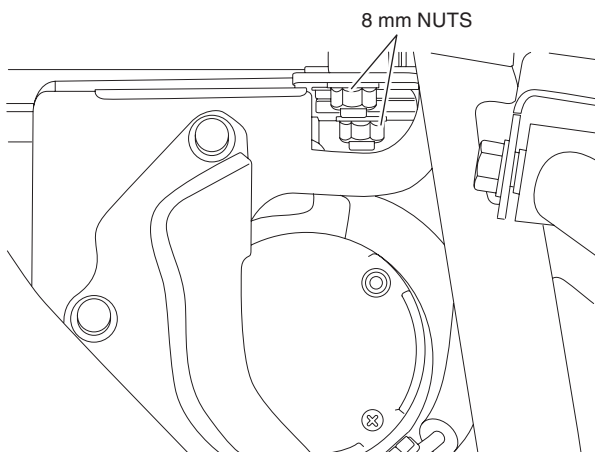

10. Feed the winch cable through the fairlead rollers and install the clevis hook assembly using the instructions provided in the Warn Winch Motor.

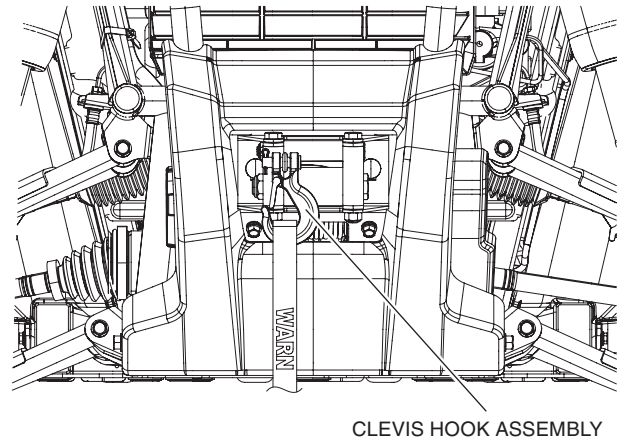

11. Proceed to ELECTRICAL INSTALLATION.

ELECTRICAL INSTALLATION

1. Remove hood by turning knobs in an outward direction and then pulling up by the knobs as shown.

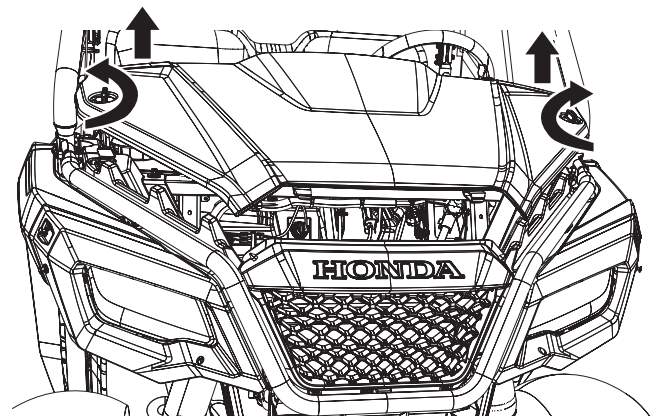

2. Refer to the Service Manual for the vehicle and remove the following components in order.

- Intake air duct
- Battery cover and battery
- Seat (cushion and backrest)
- Seat bottom cover (right and left)
- Seat rear cover
- Rear floor cover
- Front floor cover

3. Raise the cargo bed and release the following items from the back side of the battery box as shown:

NOTE: Release the each item by releasing its anchor/clip from the battery box.

- Parking brake cable clip
- Gear position switch (8P Gray) connector
- Engine sub-harness (6P Black) connector
- CKP sensor (2P Gray) connector
- Disconnect the alternator (3P Gray) and regulator/rectifier (3P Black) connectors
- All cable clips anchored to the back side of the battery box

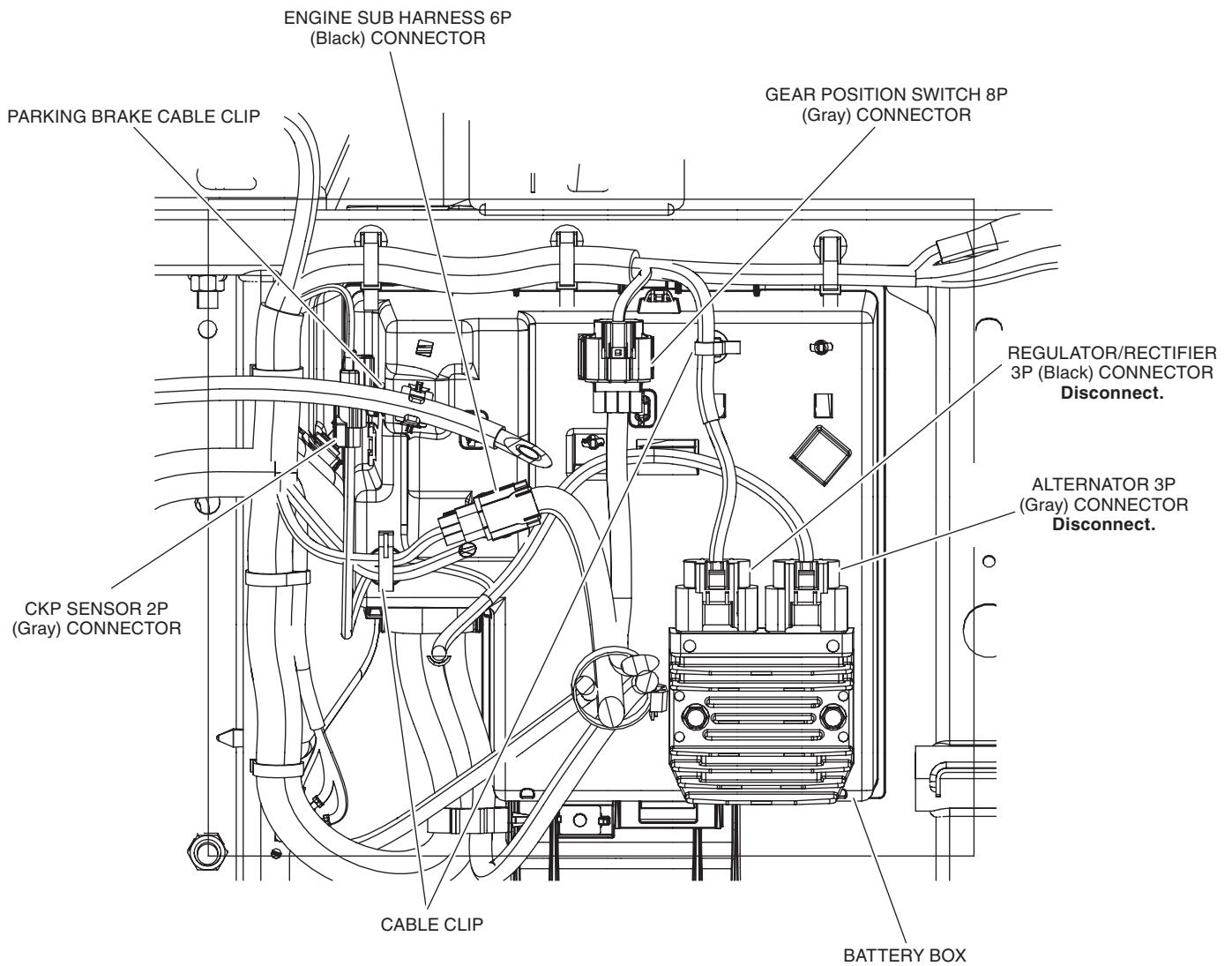

- Disconnect the battery positive (+) cable from the starter relay switch.

Release the starter relay switch body holder from its clip.

BATTERY POSITIVE CABLE

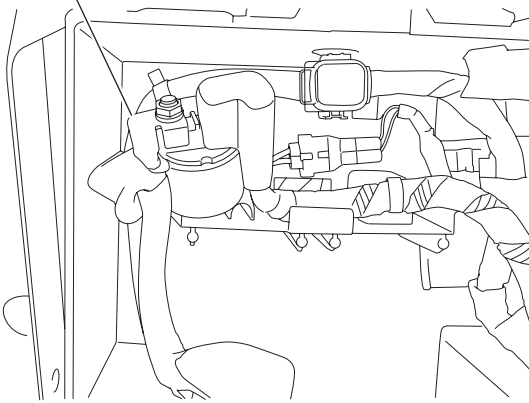

- Release the following from the inside of the batterybox by releasing their mounting clips:
 - Fuse block
 - 40 A fuse holder
 - Starter relay switch (2P Black) connector
 - Cable clip

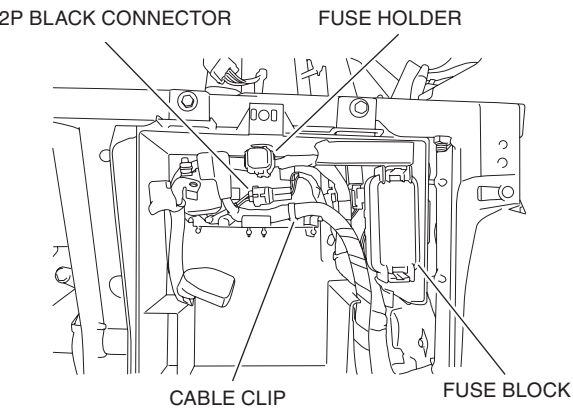

- Remove the four bolts and the battery box.

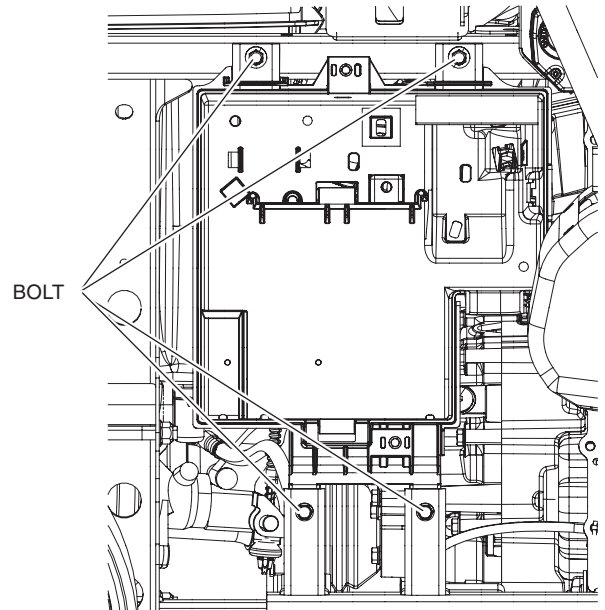

- Measure and mark a horizontal line 202 mm up from the bottom and a vertical line 47 mm from the front edge, as shown. Mark the rear-facing panel of the battery box at the intersection of the lines.

<BATTERY BOX, VIEW FROM REAR>

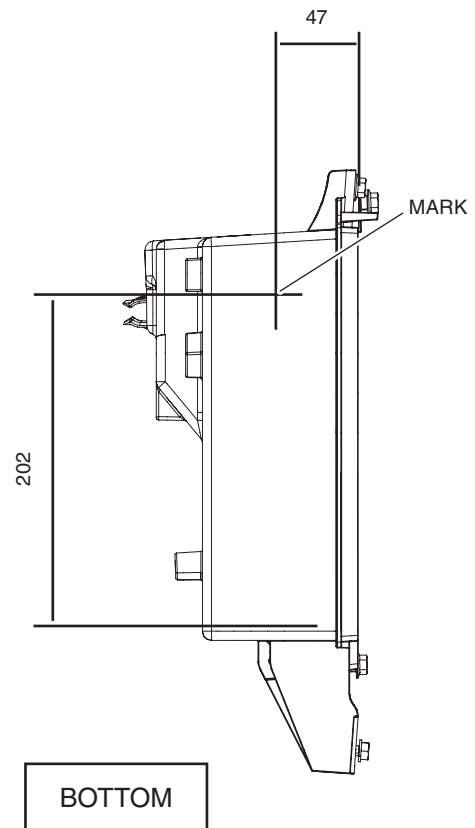

- Using a 30 mm hole saw, cut a hole in the battery box at the marked point. Install the rubber grommet with the sleeve oriented at the indicated angle as shown.

<BATTERY BOX, VIEW FROM REAR>

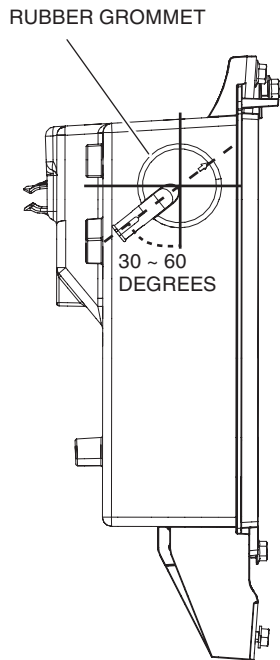

- Reinstall the battery box, related components, and battery in the reverse order of removal.

Do not reconnect the battery positive (+) cable to the starter relay switch at this time.

- Locate the DLC (4P Red) connector and remove the connector from the dummy cap. Be sure to leave the dummy cap taped to the main wire harness.

<VIEW UNDER FRONT HOOD>

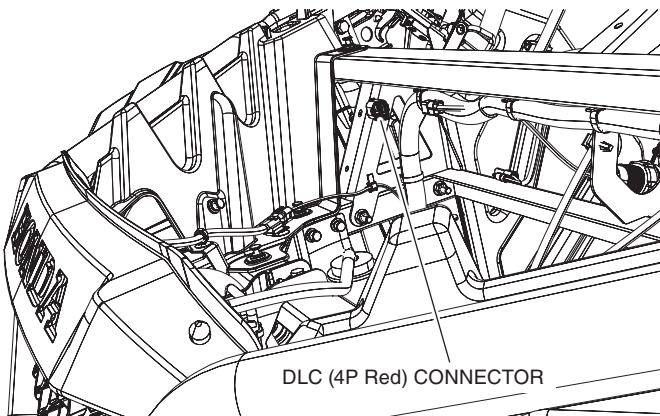

- Connect the Accessory Sub-Harness to the DLC (4P Red) connector as shown.

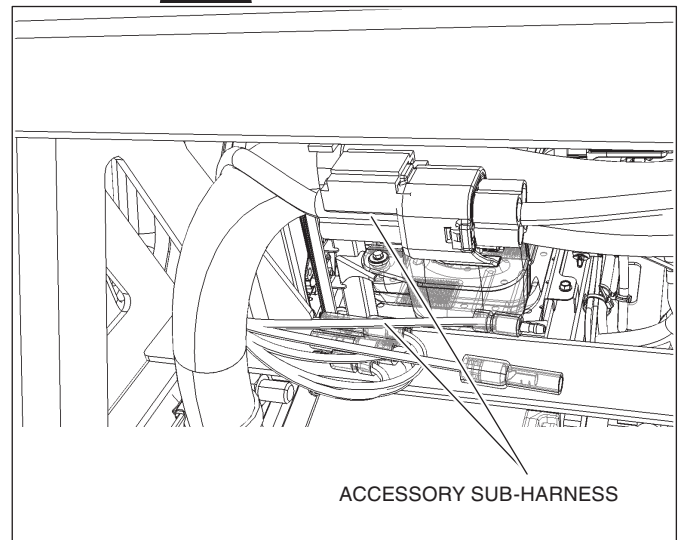
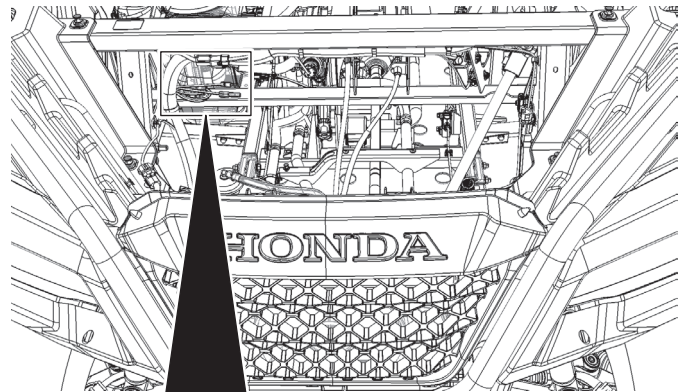

- Disconnect the combination meter sub-harness 10P (Gray) connector.

Remove the four screws, two special bolts and combination meter/rear cover assembly.

<VIEW UNDER FRONT HOOD>

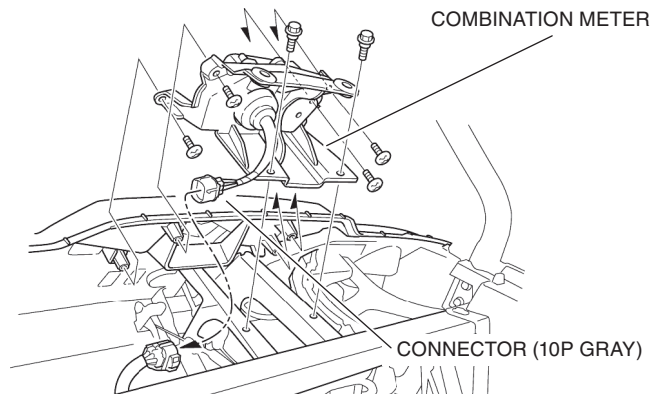

13. Using the molded template on the back side of the instrument panel, make a starter hole with the 5/8 inch step drill and then enlarge the cut-out for the winch switch using a rotary tool and carbide burr.

NOTE: When making the hole for the winch switch with the carbide burr, leave the outline unbroken and then use a file to finish the hole.

<VIEW UNDER HOOD, BACK SIDE OF INSTRUMENT PANEL>

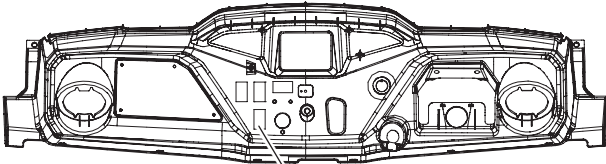

WINCH SWITCH TEMPLATE
Cut out.

14. Install the Winch Switch into the cut-out in the instrument panel as shown.

<INSTRUMENT PANEL, VIEW FROM INSIDE THE CAB>

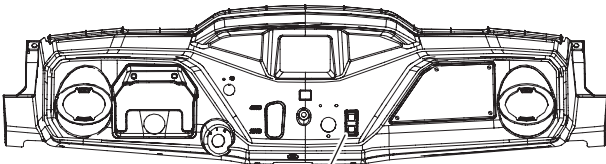

WINCH SWITCH LOCATION

15. Reinstall the combination meter in the reverse order of removal.

16. Pre-assemble the Contactor and Stay as shown.

Parts required for assembly:

- Contactor stay
- Special Bolt, 5 mm
- Rubber washer
- Flange nut, 5 mm
- Contactor

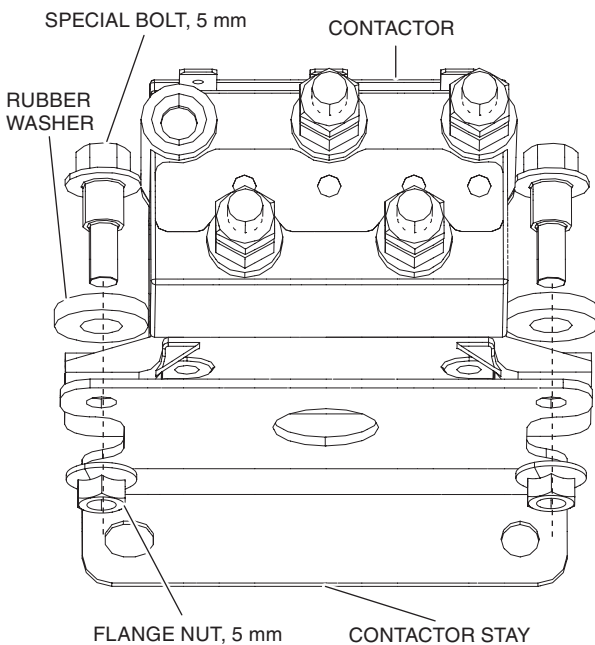

17. Install the Contactor Stay Assembly to the frame crossmember with two 6 x 12 mm flange bolts and two 6 mm lock nuts as shown.

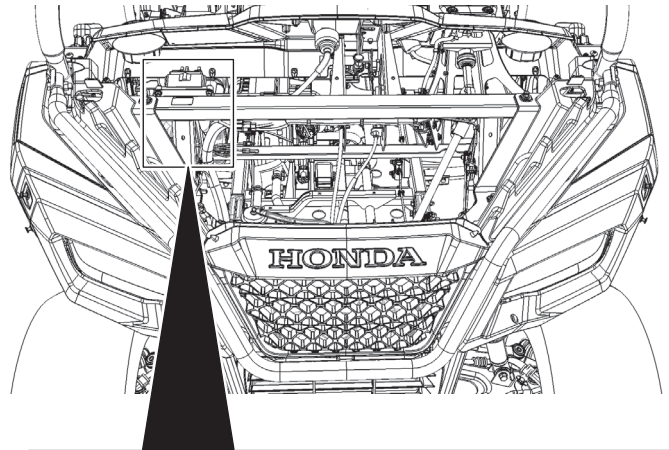

<CONTACTOR, VIEW FROM BACK>

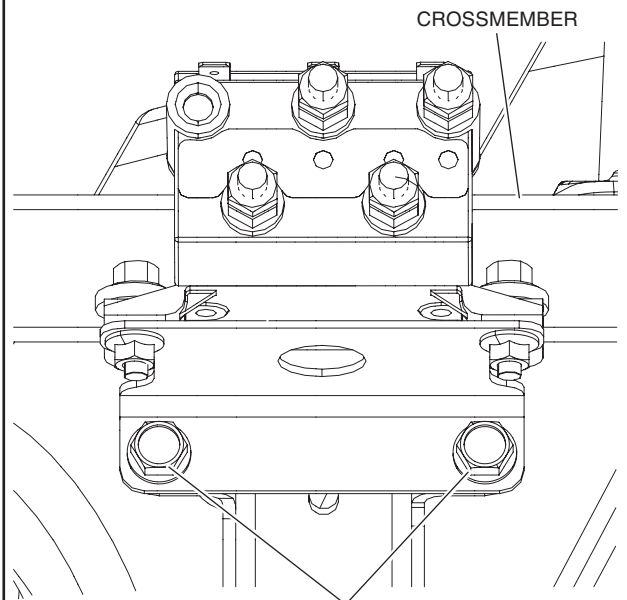

FLANGE BOLT, 6 x 12 mm

<CONTACTOR, VIEW FROM FRONT>

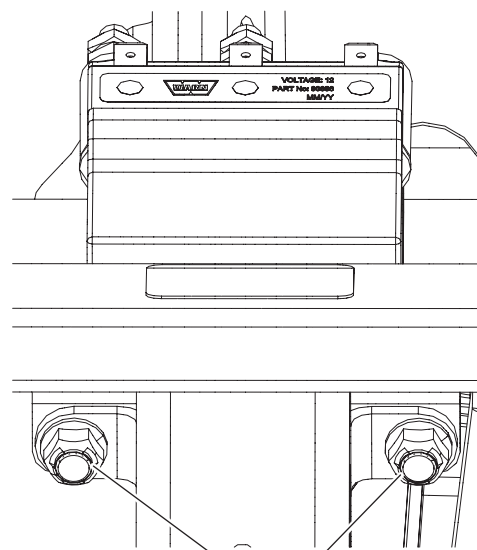

SELF LOCK NUT, 6 mm

CONNECTION DIAGRAM

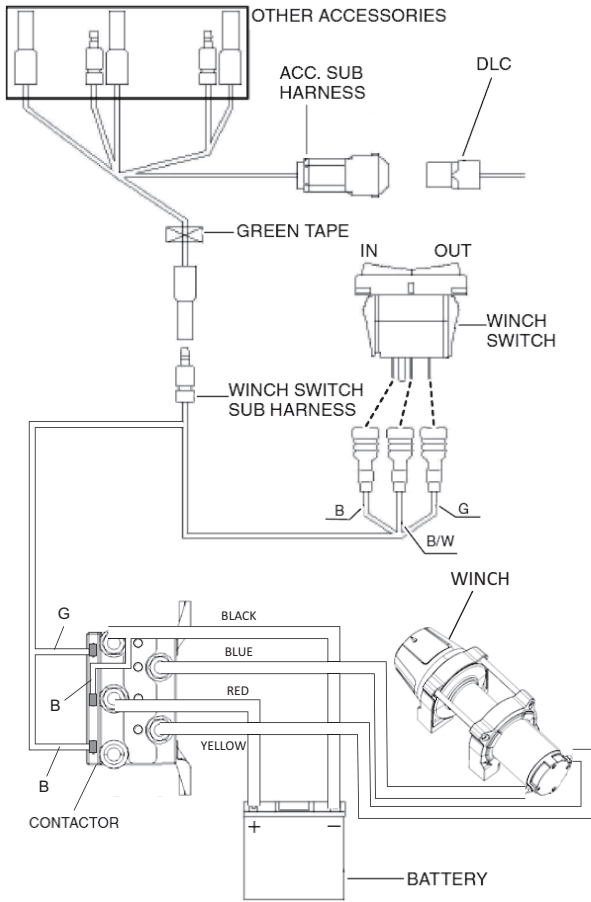

18. Connect the Winch Switch Sub-Harness to the green tape wire of the Accessory Sub-Harness as shown. The other connections will be made in later steps.

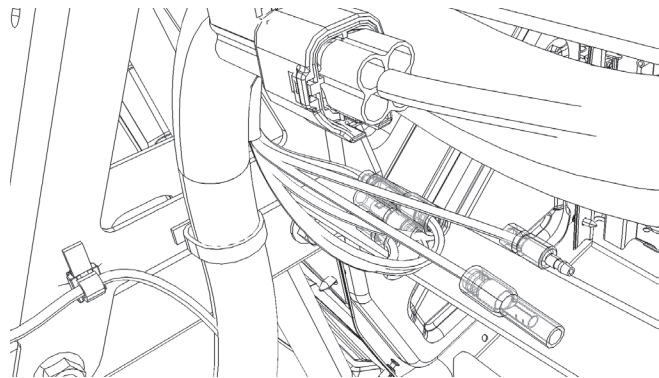

19. Connect the Winch Switch Sub-Harness to the Winch Switch as shown.

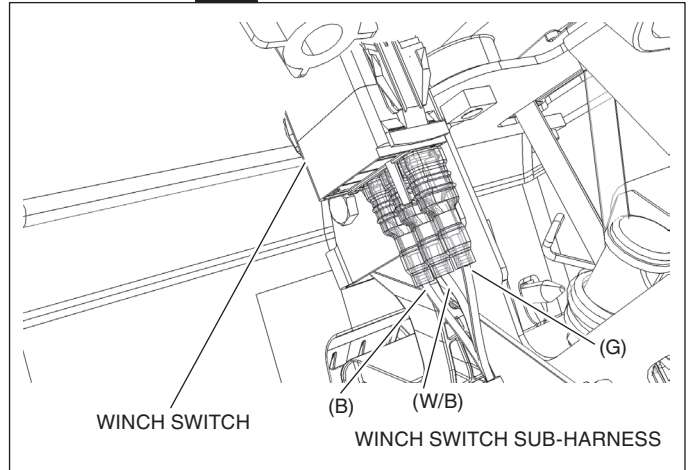
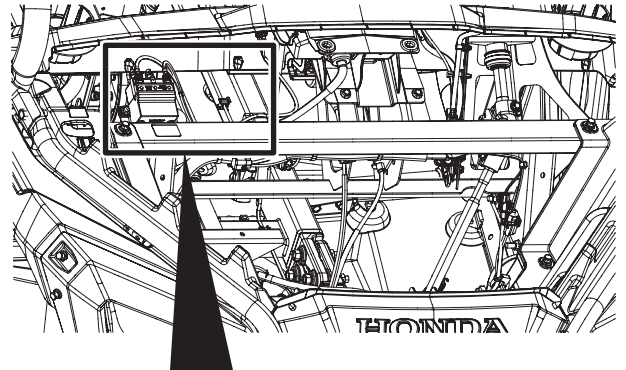

20. Connect the Winch Switch Sub Harness to the Contactor as shown.

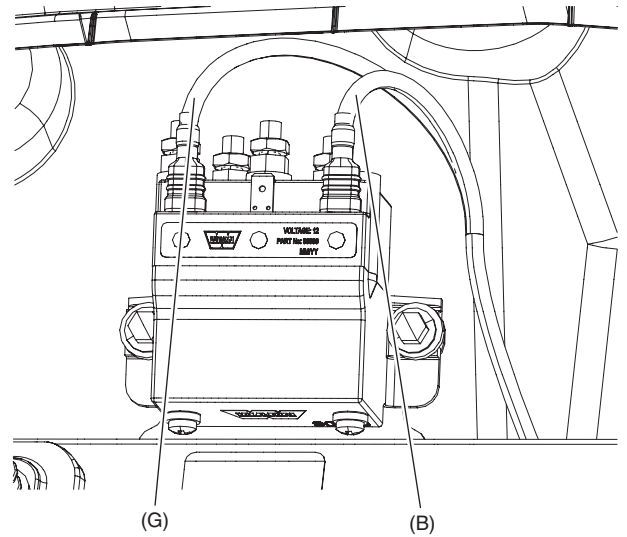

21. Secure the Winch Switch Sub Harness with wire ties in the positions shown.

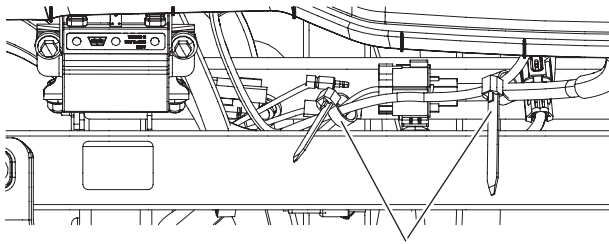

WIRE TIE (SHORT)

22. Route the yellow and blue power cables as shown and secure them with wire ties in the positions shown.

<FRAME TRANSPARENT TO SHOW ROUTING>

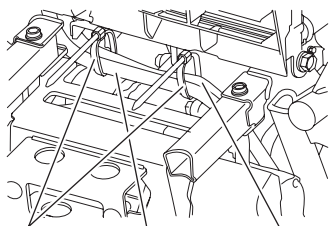

WIRE TIE (LONG)
YELLOW POWER CABLE
BLUE POWER CABLE

23. Continue routing the yellow and blue power cables as shown and secure them with wire ties in the positions shown. Make sure cables do not contact lower radiator mount brackets in the locations shown.

<FRAME TRANSPARENT TO SHOW ROUTING>

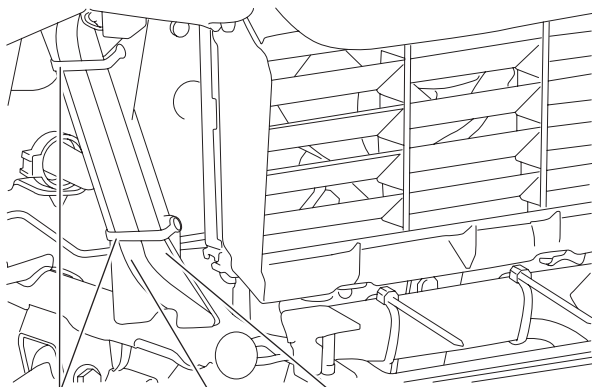

WIRE TIE (LONG)
YELLOW POWER CABLE
BLUE POWER CABLE

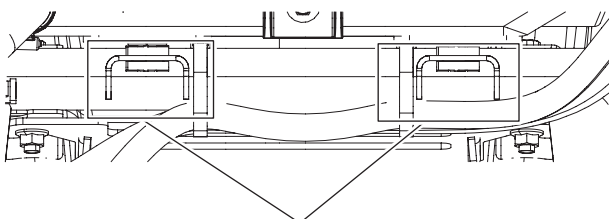

LOWER RADIATOR MOUNT BRACKETS

24. Continue routing the yellow and blue power cables as shown and secure them with wire ties in the positions shown.

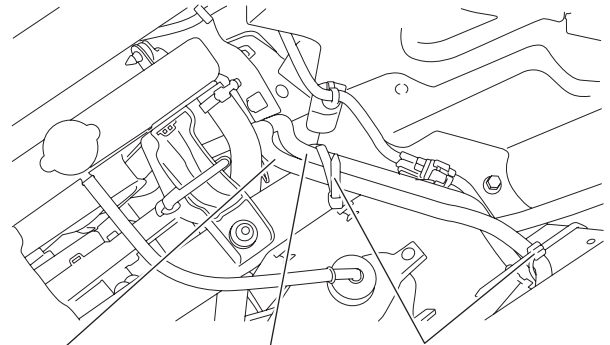

YELLOW POWER CABLE
WIRE TIE (LONG)
BLUE POWER CABLE

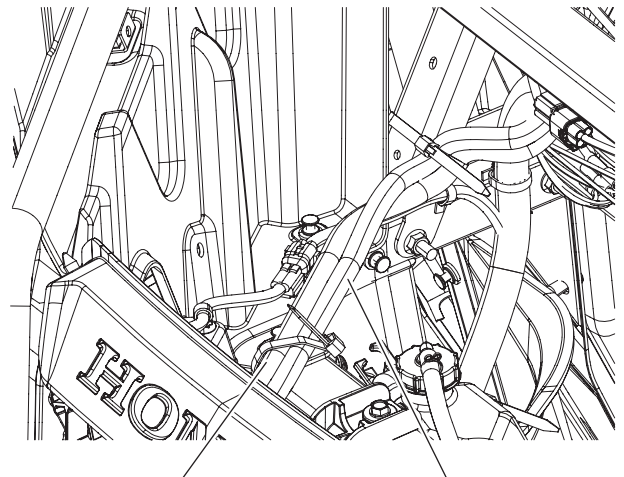

BLUE POWER CABLE
YELLOW POWER CABLE

25. Connect the yellow and blue power cables to the corresponding color terminals of the Contactor as shown.

Connect the red (battery) cable and black (ground) cable to the corresponding color terminals of the Contactor as shown.

Connect the black (ground) wire to the brown color terminal of the Contactor as shown.

Pull the terminal boots over the terminals and nuts.

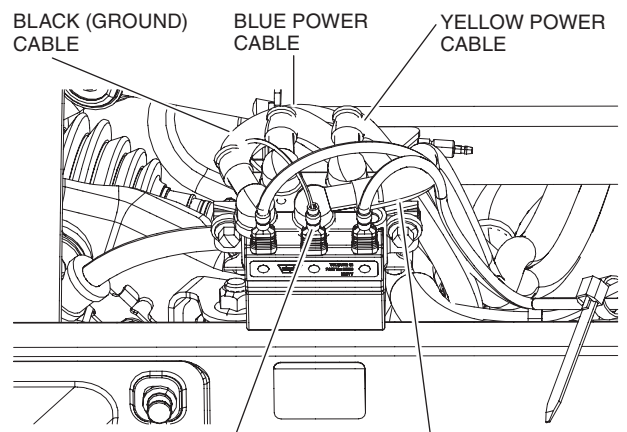

BLACK (GROUND) CABLE
BLUE POWER CABLE
YELLOW POWER CABLE
BLACK (GROUND) WIRE (BROWN DOT)
RED (BATTERY) CABLE

26. Install the wire tie at the position shown around the main wire harness and all of the winch cables.

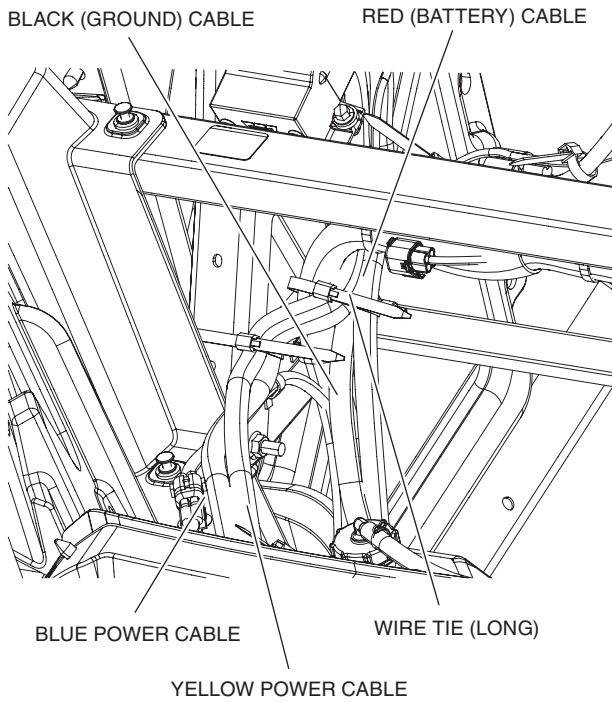

27. Route the red and black cables and secure them with wire ties in the positions shown.

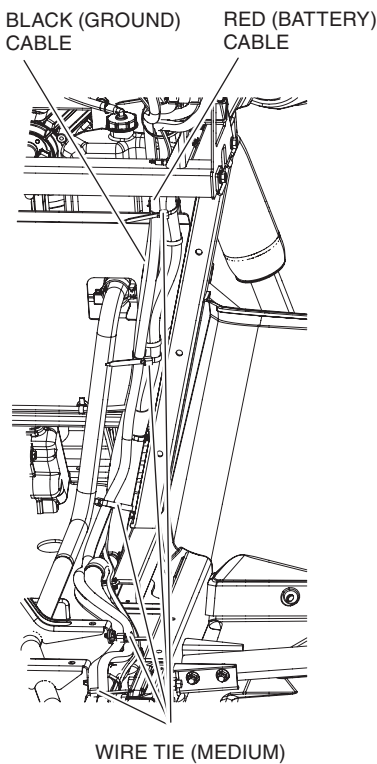

28. Continue routing the red and black cables and secure them with wire ties in the positions shown.

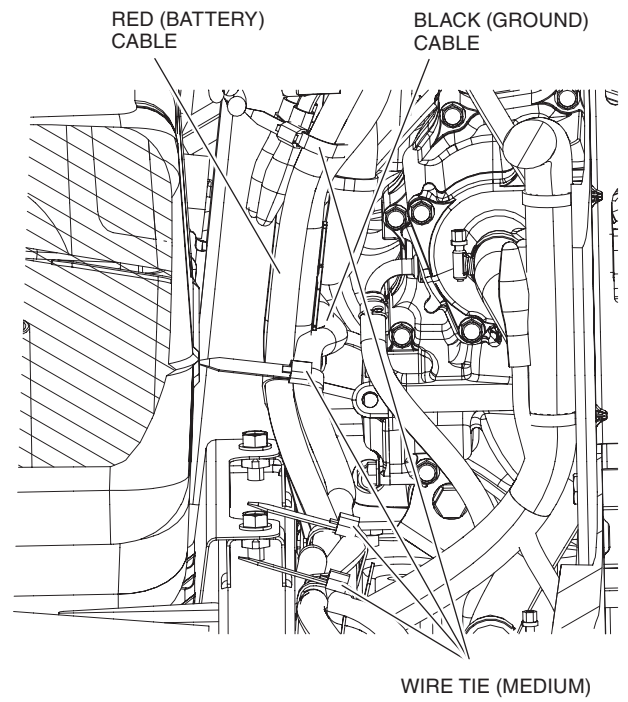

29. Route the red cable up and along the back side of the battery box as shown.

Secure the red cable with wire ties in the positions shown.

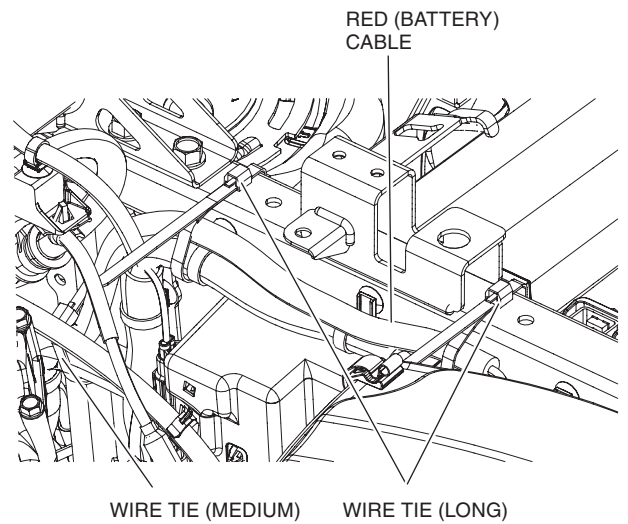

30. Route the red cable into the rubber grommet as shown.

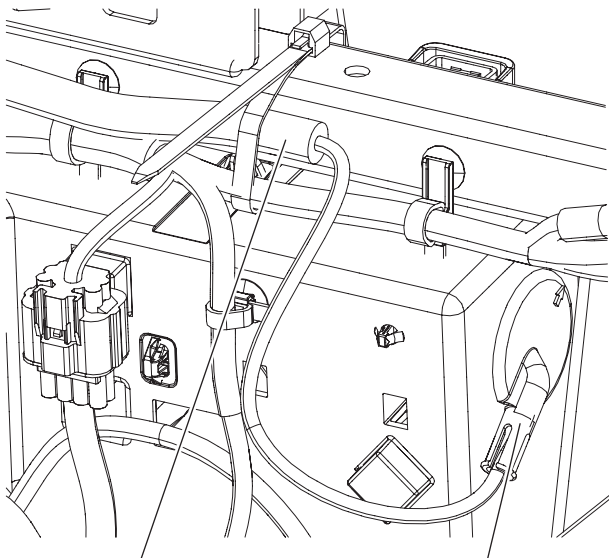

RED (BATTERY)
CABLE

BATTERY BOX
Rubber Grommet.

31. Install the battery positive (+) cable and the red winch cable to the starter relay switch terminal and then tighten the terminal nut securely.

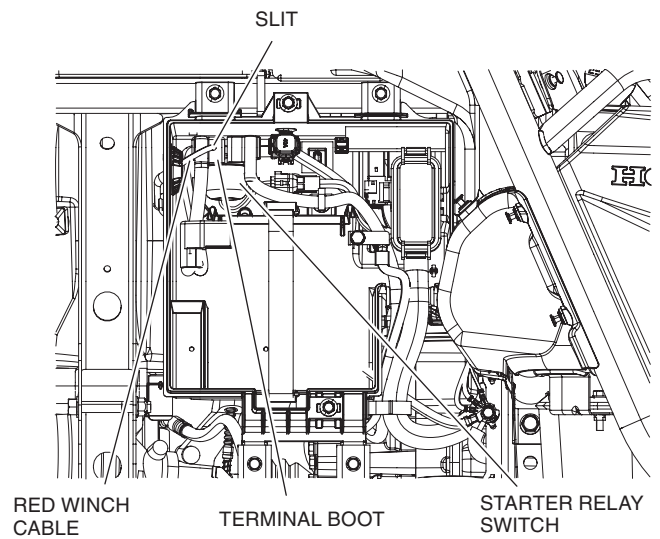

RED WINCH
CABLE

TERMINAL BOOT

STARTER RELAY
SWITCH

NOTE: Slit the terminal boot at the dimensions shown to allow the boot to accept the red winch cable.

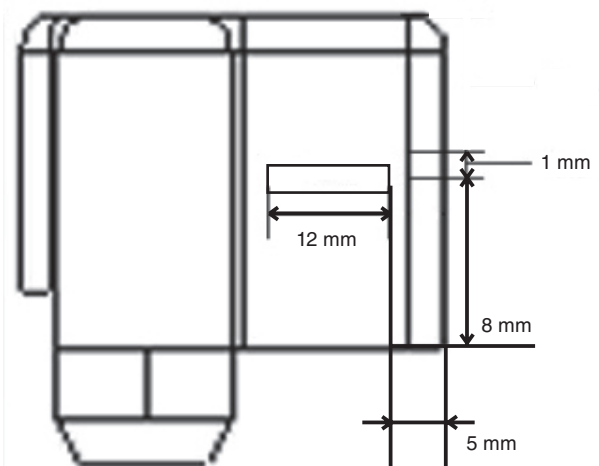

32. Route the black winch cable toward the chassis ground as shown.

Remove the ground terminal bolt and pass it through the terminal in the black winch cable.

Reinstall the ground terminal bolt and tighten it securely while making sure the black winch cable does not touch the frame edge.

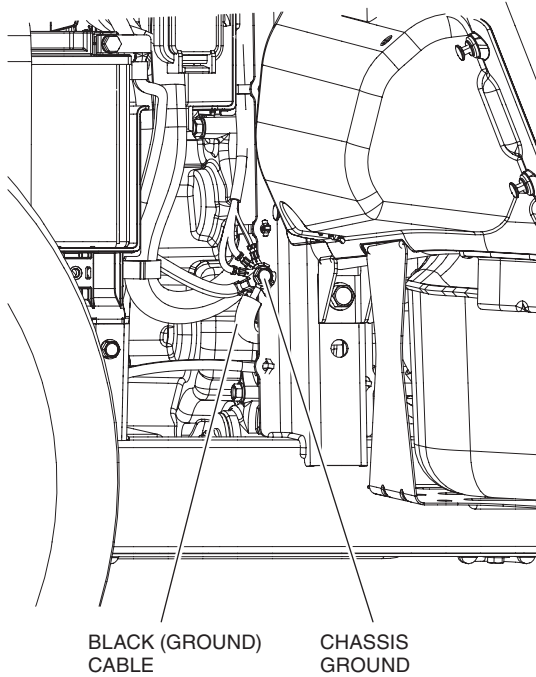

CHECK THE SYSTEM

Before using the winch, verify the following:

- The wiring to all components is correct. All loose wires are secured with zip-ties.
- There are no exposed wiring or terminals (except the chassis ground bolt). Cover any existing terminal exposures with terminal boots, heat shrink tubing, or electrical tape.
- Turn the vehicle ignition switch to the ON position. Check the winch for proper operation. The wire rope should spool in and out in the direction indicated on the switch.

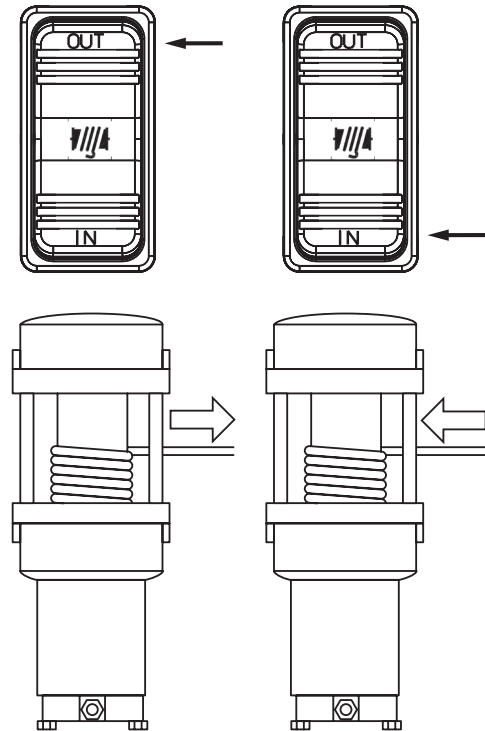

33. Refer to the Service Manual for the vehicle and reinstall the removed components.

- Front floor cover
- Rear floor cover
- Seat rear cover
- Seat bottom cover (right and left)
- Seat (cushion and backrest)
- Battery cover
- Intake air duct
- Hood